



- design according to BS 5351
- floating ball with L or T port, PTFE seats
- ISO 5211 top flange
- fire safe BS 6755, API 6FA, API 607

APPLICATION

- piping systems for processing, treatment and transport of liquid or gaseous media

ADVANTAGES

- low weight
- space saving construction
- easy installation and maintenance
- reliability
- possibility of automatic operation

TECHNICAL DATA

Working fluid:	non-aggressive liquids and gases (water, steam, oil, air, fuel gases, oil and oil derivatives) depending on construction materials of valve
Working temperature:	from -10 °C to +180 °C (A105, PTFE) from -20 °C to +180 °C (AISI 316, PTFE)
Max. working pressure:	1,6 MPa, more in Pressure/Temperature Diagram
Construction materials:	more in table of Materials of main construction parts
Face to face:	acc. to manufacturer
Mounting:	between flanges acc. to EN 1092-1, B1
Operating:	hand lever
Option:	electric or pneumatic operating DN ≥25 antistatic device degreasing service delivery including counter-flanges, sealing and bolting material
Testing:	each ball valve shall be tested in accordance with EN 12266 and supplied with accompanying documentation according to EN 10204
Certification:	PED 2014/68/ EU ATEX 94/9/ CE

DESIGN AND CONSTRUCTION MATERIALS

Fig. 1

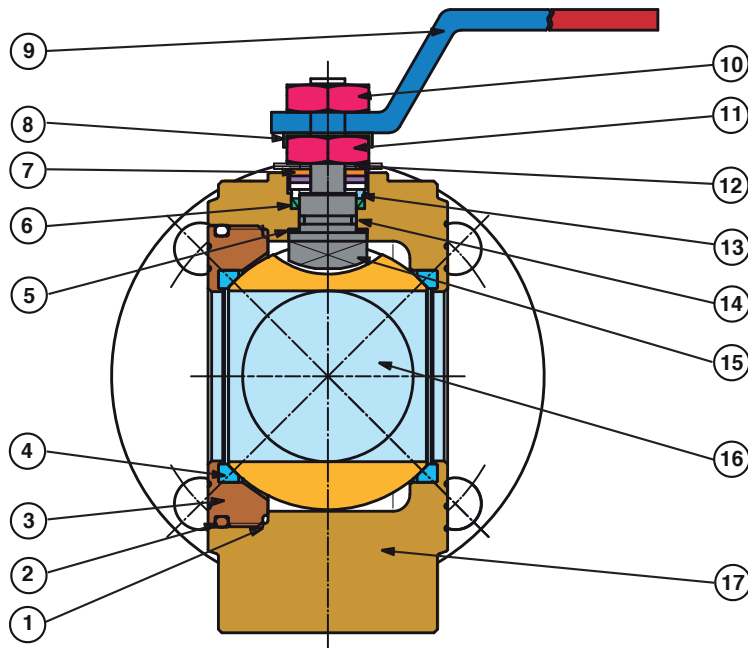
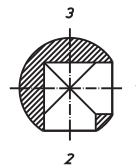
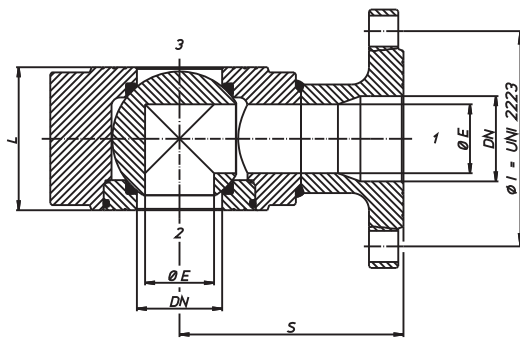
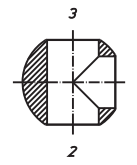

Table 1 Materials of main construction parts

Pos.	Description	Material
1	Gasket	PTFE
2	O-ring	NBR
3	2. part of body	AISI 316 ASTM A 105
4	Seats	PTFE
5	Washer	PTFE
6	Packing	PTFE
7	Operation stop	AISI 304
8	Fixing nut	AISI 304
9	Hand lever	AISI 304 Fe P02 galvaniz.
10	Locking nut	AISI 304 steel galvanized
11	Retaining ring	AISI 304 steel galvanized
12	Spring washer	AISI 301 50 Cr V4
13	Thrust washers	AISI 303
14	O-ring	FKM
15	Stem	AISI 316
16	Ball	DN 15/40 AISI 316 DN 50/100 AISI 304
17	1. part of body	AISI 316 ASTM A 105



Ball type „L“
Possible operation: 1-2, 1-3



Ball type „T“
Possible operation: 1-2-3, 1-2, 1-3

GENERAL DIMENSIONS (mm)

JADE 3W	Ø E	Ø I	L	S
DN 15	10	65	35	85
DN 20	15	75	38	90
DN 25	20	85	43	90
DN 32	25	100	54	105
DN 40	32	110	66	120
DN 50	40	125	83	130
DN 65	50	145	103	150
DN 80	65	160	122	175
DN 100	78	180	153	185

BREAKING TORQUES (Nm)

DN	15	20	25	32	40	50	65	80	100
PN (bar)	Torque (Nm)								
0	4	7	10	16	25	35	55	75	150
16	4,8	8,5	11,3	19	28	39	59	84,5	168
25	5,2	9,1	12	20,5	29,5	41,5		92	
40	6	10,5	13	22,5	31,5	44		99	

Note: For safe operation of valves with pneumatic or electric control, the relevant safety factor must be taken into account when dimensioning the actuator.

PRESSURE-TEMPERATURE DIAGRAM

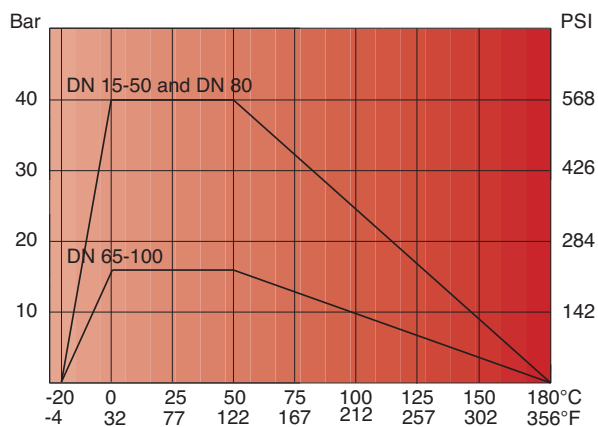

The data given in the catalog are informative and the manufacturer reserves the right to make technical changes.